

CGA Fitting Restraint Kit

TW-319

Part Number	Gas Service
XL50-9C50	Nitrogen or Argon
XL50-9C51	Oxygen
XL50-9C52	Carbon-Dioxide or Nitrogen-Oxide

Note: Highlight appropriate row

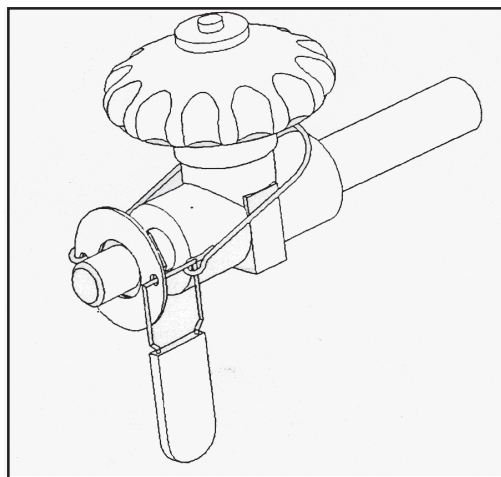

Installation Instructions

1. Select appropriate restraint for CGA fitting. Restraint washer should fit CGA fitting closely.
2. Place restraint washer over the appropriate CGA fitting.
3. Wrap resistant cable around valve stem.
4. Attach free end of cable with lock as shown above.
5. Push clasp firmly into lock body to secure.

Kits include the following parts:

Service	Kit P/N	Vent Valve Vent Restraint P/N	Liquid Valve Liquid Restraint P/N	Use Valve Use Restraint P/N
Nitrogen or Argon	XL50-9C50 set	7114-0115	7114-0115	7114-0117
Oxygen	XL50-9C51 set	7114-0116	7114-0116	7114-0116
Carbon Dioxide or Nitrous Oxide	XL50-9C52 set	7114-0115	7114-0116	7114-0116



For more information on Taylor Wharton Products

Please contact:

Atmospheric Products and Services

Attn: Patrick McCarthy Sr.

17 Norris Run Court, Reisterstown, MD 21136

Phone: 410-833-7170

Email: patrick@apsusa.biz